

SCHEDULE OF MATERIALS		
PC.	MATERIAL	REMARKS
33	STAINLESS	316L

SCHEDULE OF MATERIALS		
PC.	MATERIAL	REMARKS
1	MILD STEEL	
2	MILD STEEL	
3	COLD FINISH	
4	MILD STEEL	
5	NEOPRENE	
6	BRASS	
7	PLATED STEEL	
8	MILD STEEL	
9	COLD FINISH	
10	STAINLESS	
11	BRASS	
12	MILD STEEL	
13	DELFIN	
14	TEFLON	
15	MILD STEEL	
16	STAINLESS	
17	STAINLESS	
18	PLATED STEEL	
19	BRASS	
20	PLATED STEEL	
21	BRASS	
22	STAINLESS	
23	MILD STEEL	
24	SPRING STEEL	
25	MILD STEEL	
26	MILD STEEL	
27	MILD STEEL	
28	MILD STEEL	
29	MILD STEEL	
30	MILD STEEL	
31	MILD STEEL	
32	MILD STEEL	

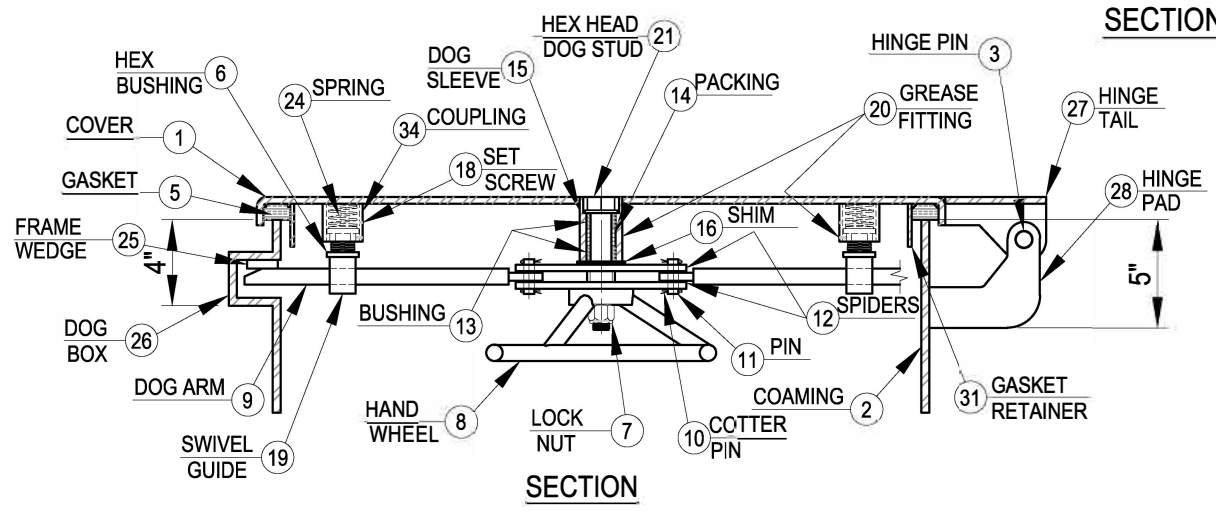
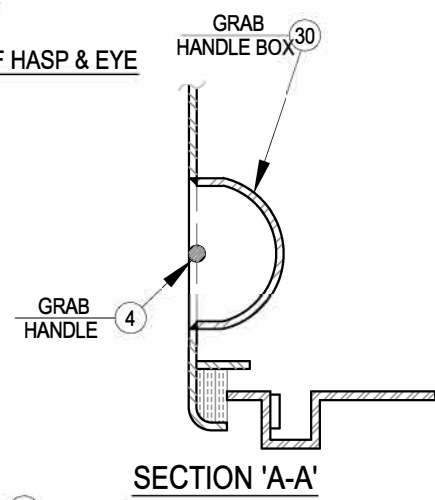
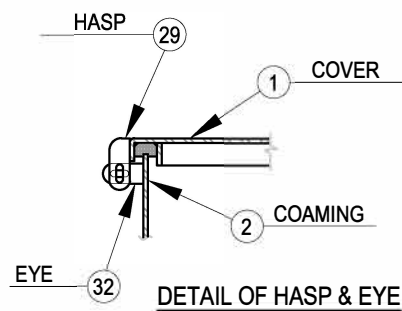

Turner Supply
 251-438-5581 or contact@turnersupply.com
 RAISED WATERTIGHT HATCH WITH FLUSH
 COVER
 DWG. NO.: 230-MS

#/O#