

PLAN

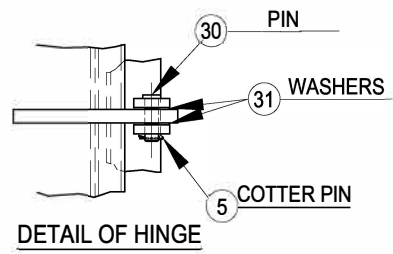

DETAIL OF HINGE

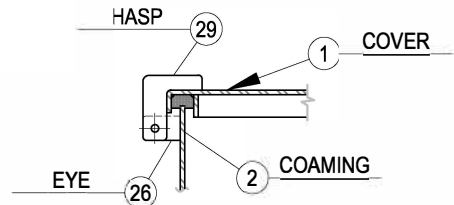

DETAIL OF HASP & EYE

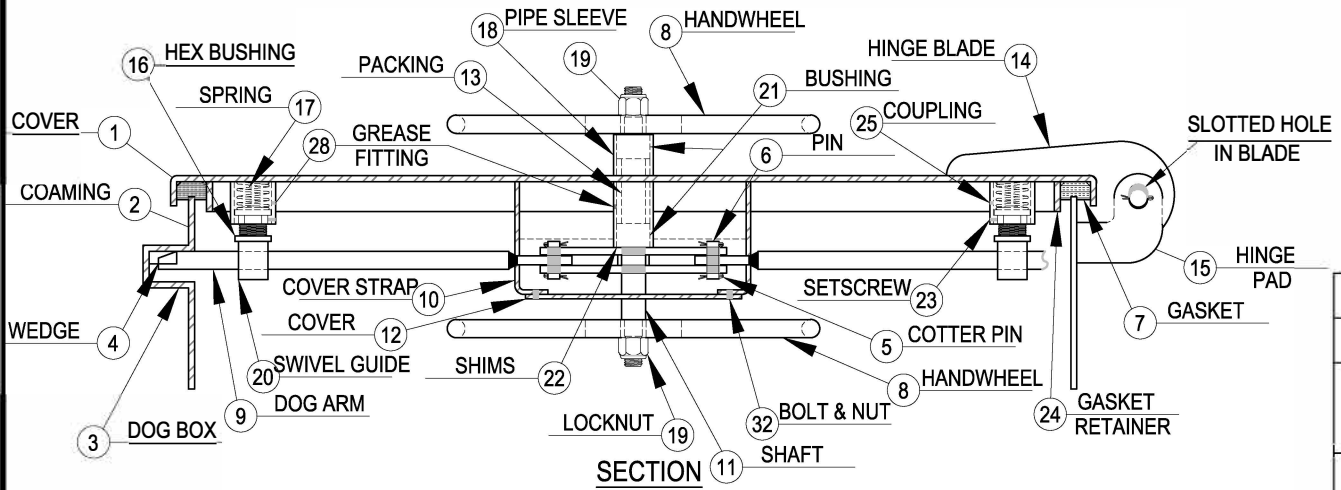

SECTION

SCHEDULE OF MATERIALS		
PC.	MATERIAL	REMARKS
1	MILD STEEL	
2	MILD STEEL	
3	MILD STEEL	
4	STAINLESS	
5	STAINLESS	
6	BRASS	
7	NEOPRENE	
8	MILD STEEL	
9	COLD FINISH	
10	MILD STEEL	
11	COLD FINISH	
12	MILD STEEL	
13	TEFLON	
14	MILD STEEL	
15	MILD STEEL	
16	BRASS	
17	PLATED STEEL	
18	MILD STEEL	
19	PLATED STEEL	
20	BRASS	
21	DELFIN	
22	STAINLESS	
23	PLATED STEEL	
24	MILD STEEL	
25	MILD STEEL	
26	MILD STEEL	
27	MILD STEEL	
28	PLATED STEEL	
29	MILD STEEL	
30	BRASS	
31	TEFLON	
32	PLATED STEEL	



Turner Supply		#/S
251-438-5581 or contact@turnersupply.com		
QUICK ACTING WATERTIGHT HATCH		
DWG. NO.: 229-MS		