

NOTES:
 1. AFTER INSTALLATION, A 1" DIAMETER DRAIN HOLE MUST BE INSTALLED AT THE LOW POINT IN THE HINGE BOX AND DRAINED OVERBOARD OR TO A SUMP TO PREVENT CORROSION OR LEAKAGE. (BY OTHERS)

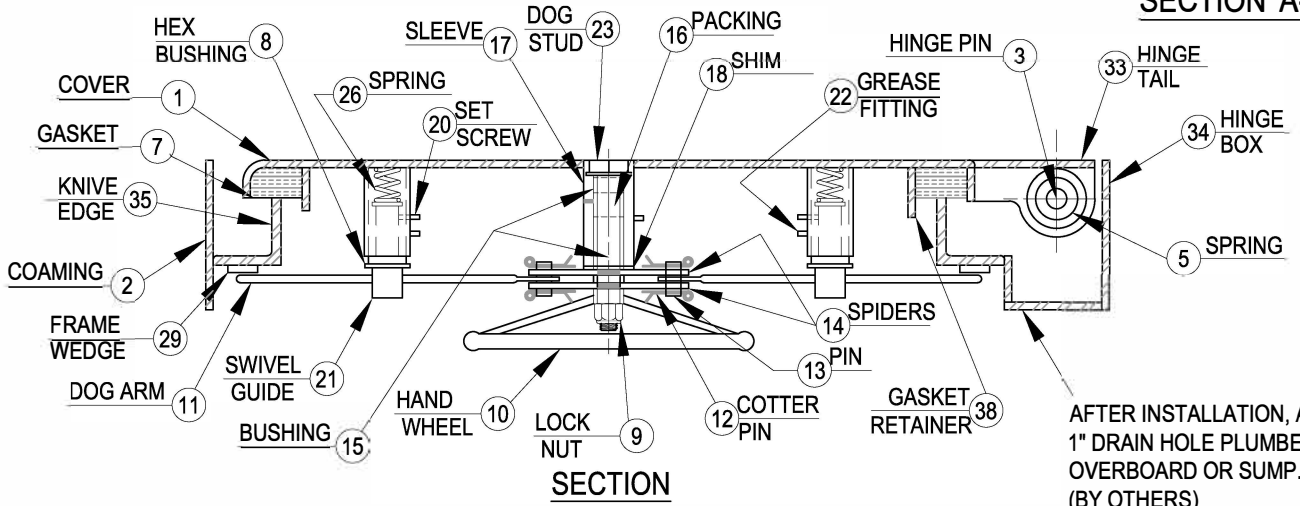
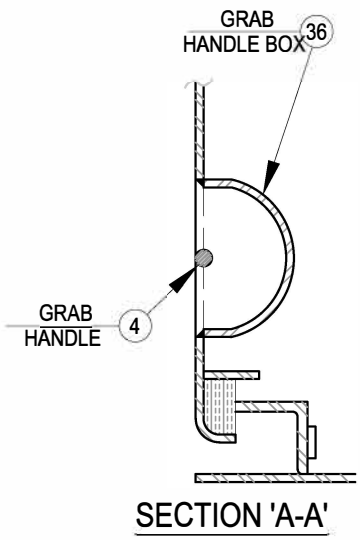

SCHEDULE OF MATERIALS		
PC.	MATERIAL	REMARKS
1	MILD STEEL	
2	MILD STEEL	
3	COLD FINISH	
4	MILD STEEL	
5	STAINLESS	
6	MILD STEEL	
7	NEOPRENE	
8	BRASS	
9	STAINLESS	
10	MILD STEEL	
11	COLD FINISH	
12	STAINLESS	
13	BRASS	
14	MILD STEEL	
15	DELFIN	
16	TEFLON	
17	MILD STEEL	
18	STAINLESS	
19	STAINLESS	
20	PLATED STEEL	
21	BRASS	
22	PLATED STEEL	
23	BRASS	
24	MILD STEEL	
25	MILD STEEL	
26	SPRING STEEL	
27	MILD STEEL	
28	PLATED STEEL	
29	STAINLESS	
30	MILD STEEL	
31	MILD STEEL	
32	BRONZE	
33	MILD STEEL	
34	MILD STEEL	
35	MILD STEEL	
36	MILD STEEL	
37	STAINLESS	316L ALLOY
38	MILD STEEL	

Turner Supply
 251-438-5581 or contact@turnersupply.com
 QUICK ACTING WATERTIGHT FLUSH HATCH
 WITH RECESSED SPRING
 DWG. NO.: 219-MS

AFTER INSTALLATION, A 1" DRAIN HOLE PLUMBED OVERBOARD OR SUMP. (BY OTHERS)