

SECTION

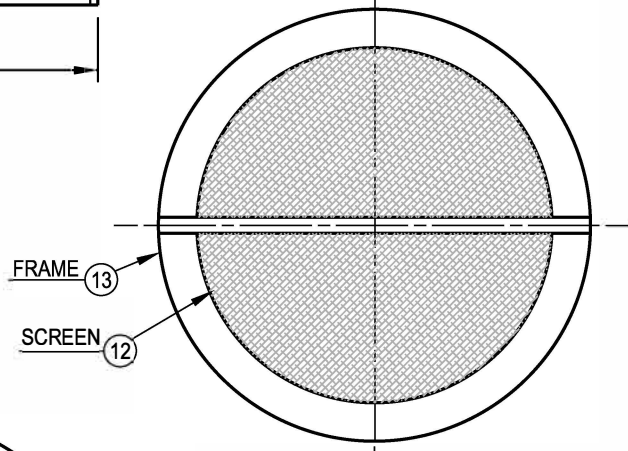

SCREEN OPTIONAL

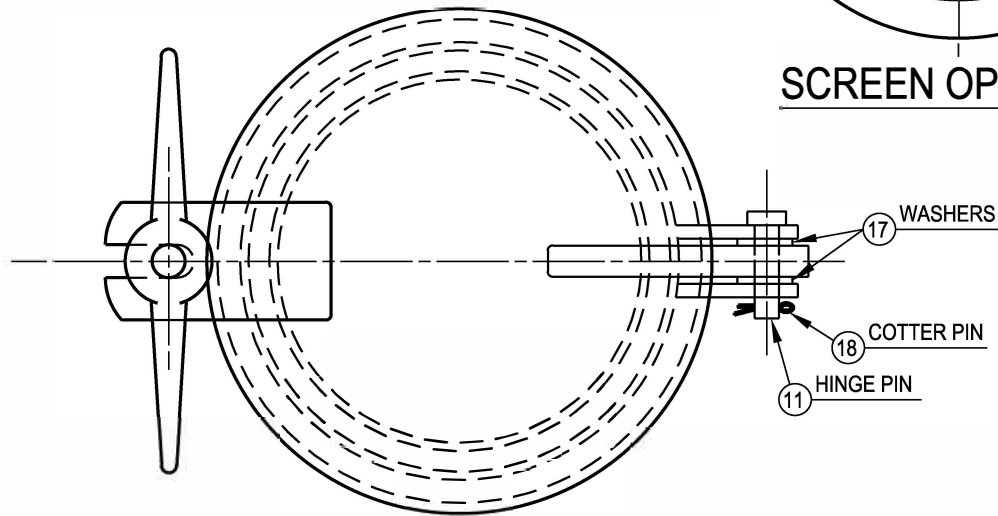

PLAN

SCHEDULE OF MATERIALS

PC.	MATERIAL	REMARKS
1	MILD STEEL	
2	MILD STEEL	
3	MILD STEEL	
4	MILD STEEL	
5	MILD STEEL	
6	MANGANESE BRONZE	
7	STAINLESS	
8	MANGANESE BRONZE	
9	BRASS	
10	MILD STEEL	
11	BRASS	
12	STAINLESS	
13	STAINLESS	
14	MILD STEEL	
15	NEOPRENE	
16	MILD STEEL	
17	STAINLESS	
18	STAINLESS	



TURNER SUPPLY
SERVING INDUSTRY SINCE 1905

Turner Supply
251-438-5581 or contact@turnersupply.com
ULLAGE HATCH
DWG. NO.: 218-MS