

PLAN

NOTES:

1. AFTER INSTALLATION, A 1" DIAMETER DRAIN HOLE MUST BE INSTALLED AT THE LOW POINT IN THE HINGE BOX AND DRAINED OVERBOARD OR TO A SUMP TO PREVENT CORROSION OR LEAKAGE. (BY OTHERS)

SCHEDULE OF MATERIALS

PC.	MATERIAL	REMARKS
1	MILD STEEL	
2	MILD STEEL	
3	COLD FINISH	
4	MILD STEEL	
5	NEOPRENE	
6	MILD STEEL	
7	FORGED STEEL	
8	STAINLESS	
9	BRASS	
10	STAINLESS	
11	DELTRIN	
12	MANGANESE BRONZE	
13	MILD STEEL	
14	TEFLON	
15	MILD STEEL	
16	MILD STEEL	
17	MILD STEEL	
18	STAINLESS	
19	MILD STEEL	
20	MILD STEEL	
21	PLATED STEEL	
22	PLATED STEEL	
23	MILD STEEL	
24	MILD STEEL	
25	MILD STEEL	
26	MILD STEEL	
27	MILD STEEL	
28	STAINLESS	316L ALLOY
29	BRONZE	

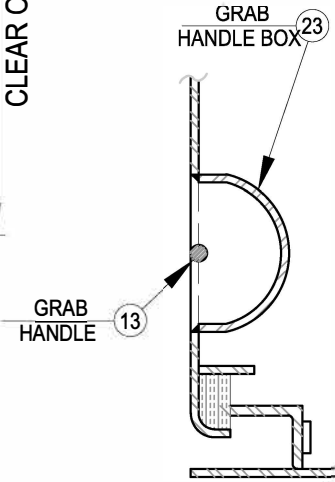

SECTION 'X-X'

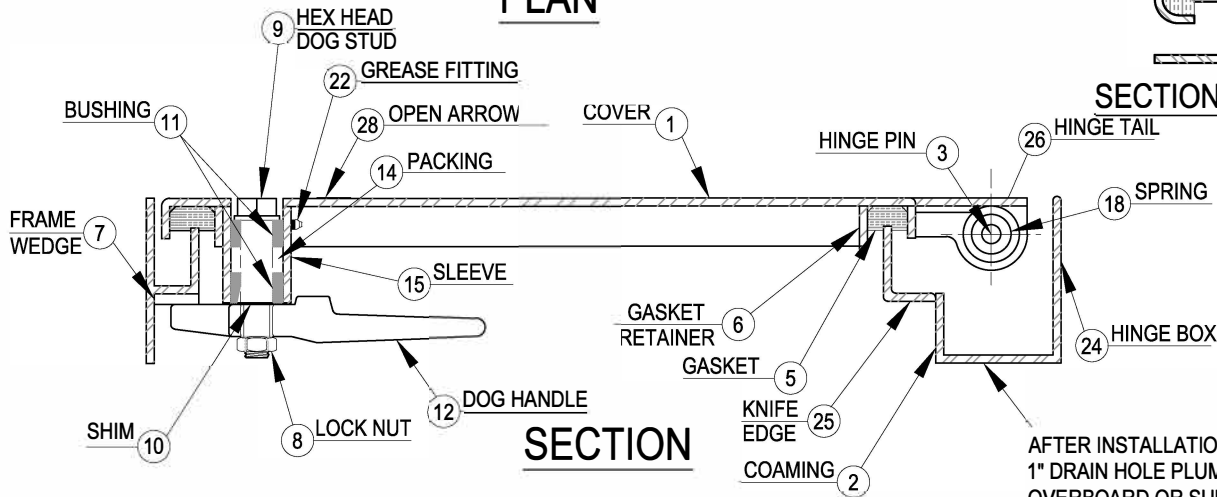

SECTION

AFTER INSTALLATION, A 1" DRAIN HOLE PLUMBED OVERBOARD OR SUMP. (BY OTHERS)



Turner Supply

251-438-5581 or contact@turnersupply.com

WATERTIGHT FLUSH HATCH W/ SPRING ASSIST COVER & RECESSED SPRING

DWG. NO.: 217-MS