

PLAN

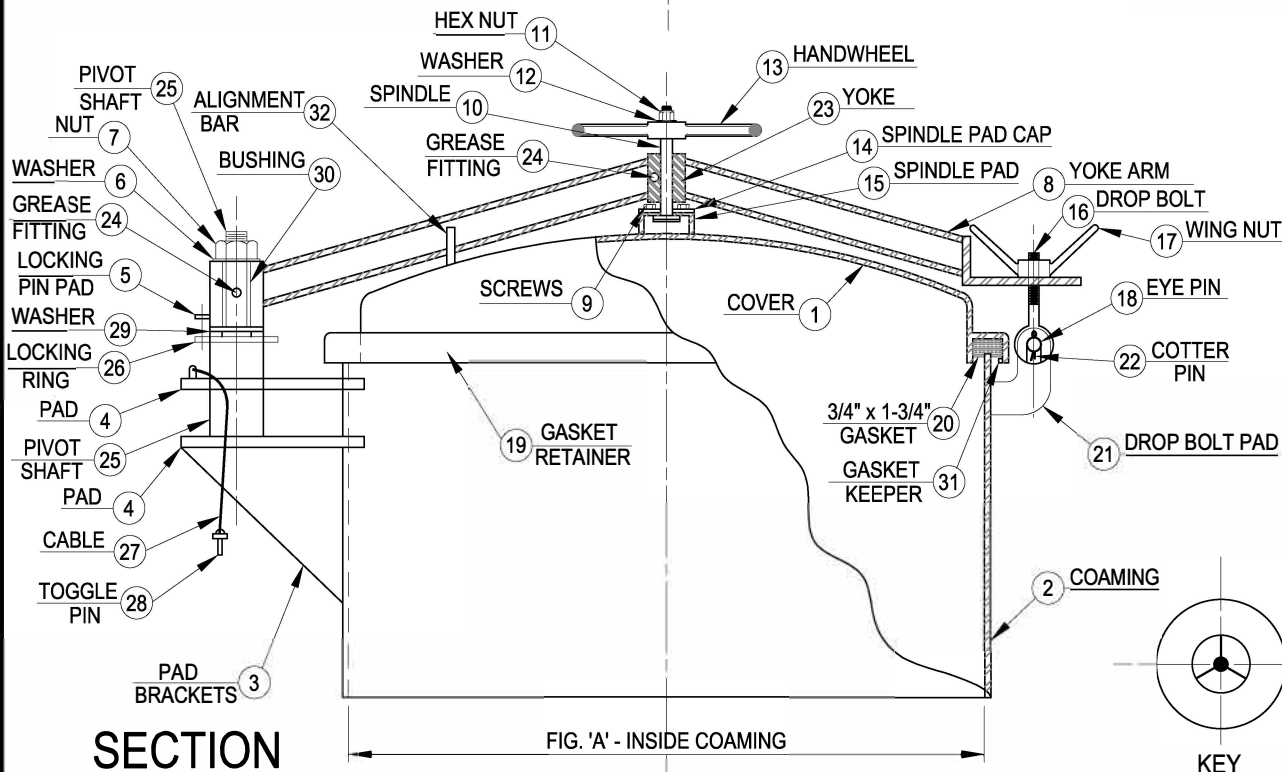

SECTION

FIG. 'A' - INSIDE COAMING

KEY

| SCHEDULE OF MATERIALS | | |
|-----------------------|------------------|---------|
| PC. | MATERIAL | REMARKS |
| 1 | MILD STEEL | |
| 2 | MILD STEEL | |
| 3 | MILD STEEL | |
| 4 | MILD STEEL | |
| 5 | MILD STEEL | |
| 6 | PLATED STEEL | |
| 7 | PLATED STEEL | |
| 8 | MILD STEEL | |
| 9 | STAINLESS | |
| 10 | BRASS | |
| 11 | PLATED STEEL | |
| 12 | STAINLESS | |
| 13 | MILD STEEL | |
| 14 | MILD STEEL | |
| 15 | MILD STEEL | |
| 16 | MANGANESE BRONZE | |
| 17 | MANGANESE BRONZE | |
| 18 | BRASS | |
| 19 | MILD STEEL | |
| 20 | NEOPRENE | |
| 21 | MILD STEEL | |
| 22 | STAINLESS | |
| 23 | STEEL | |
| 24 | PLATED STEEL | |
| 25 | STEEL | |
| 26 | STEEL | |
| 27 | STAINLESS | |
| 28 | STAINLESS | |
| 29 | PLATED STEEL | |
| 30 | BRASS | |
| 31 | STEEL | |
| 32 | STEEL | |



Turner Supply
 251-438-5581 or contact@turnersupply.com
OIL CARGO HATCH
 DWG. NO.: 210-MS