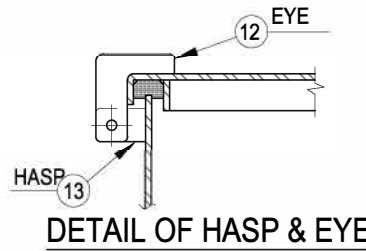
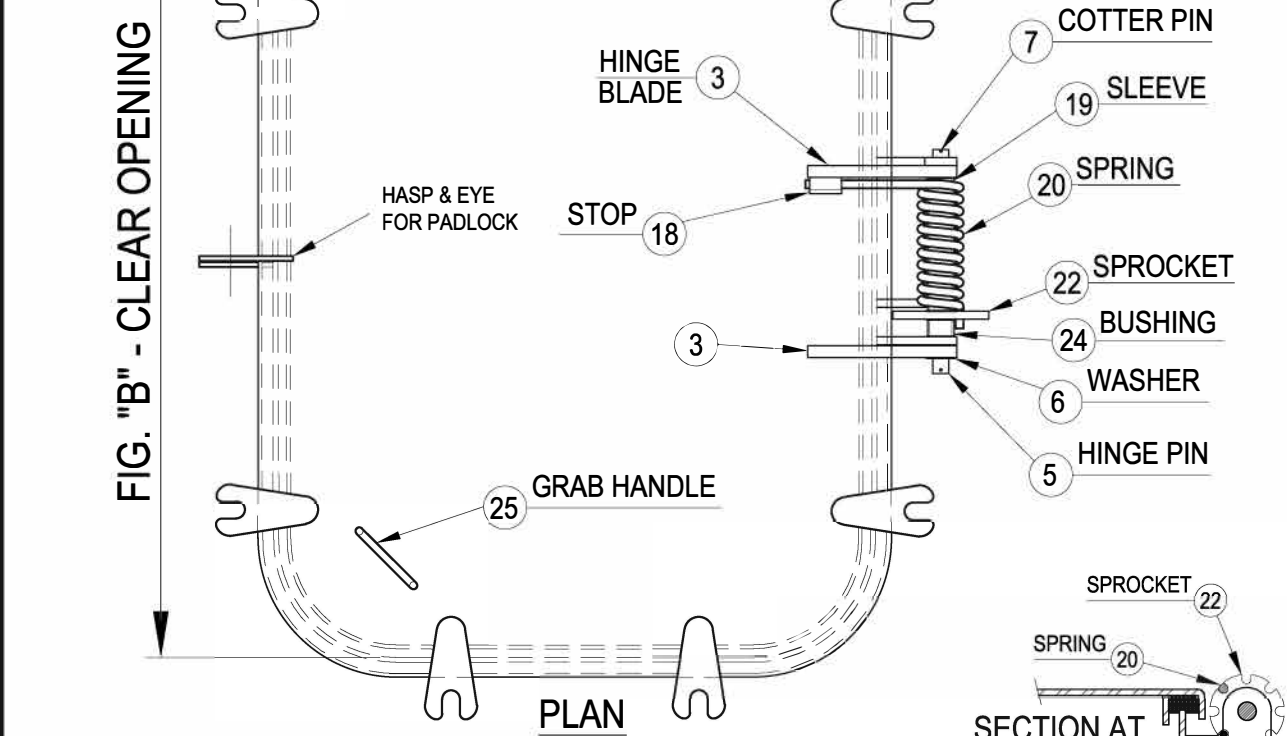

FIG. "A" - CLEAR OPENING



DETAIL OF HASP & EYE

FIG. "B" - CLEAR OPENING



PLAN

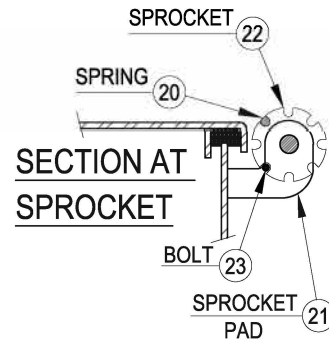

SECTION AT SPROCKET

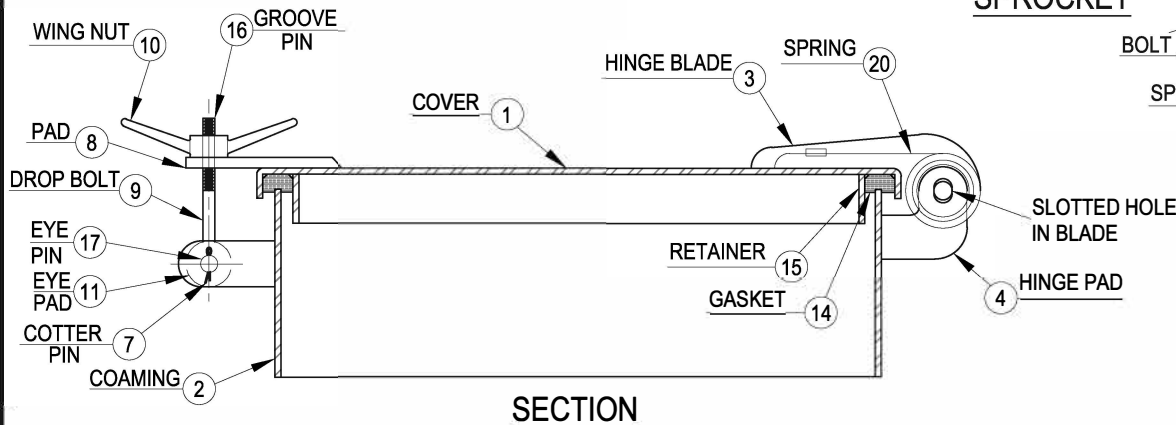

SECTION

SCHEDULE OF MATERIALS

PC.	MATERIAL	REMARKS
1	MILD STEEL	
2	MILD STEEL	
3	MILD STEEL	
4	MILD STEEL	
5	STEEL	
6	STAINLESS	
7	STAINLESS	
8	STEEL	
9	MANGANESE BRZ	
10	MANGANESE BRZ	
11	MILD STEEL	
12	MILD STEEL	
13	MILD STEEL	
14	NEOPRENE	
15	MILD STEEL	
16	STAINLESS	
17	BRASS	
18	STEEL	
19	STEEL	
20	STAINLESS	
21	STEEL	
22	STEEL	
23	PLATED STEEL	
24	BRASS	
25	MILD STEEL	



Turner Supply
 251-438-5581 or contact@turnersupply.com
**RAISED WATERTIGHT WITH DROP BOLTS
 AND SPRING ASSIST HATCH**
 DWG. NO.: 207-MS